



ValvEngineering SRL is a specialist in the development and supply of valves, valve related services and custom accessories destined for powder handling applications in the Pharmaceutical industry. Our relentless drive to improve the product and to invent new ones, means that we will always have something new to show the end user. The products themselves are beautifully made on the latest numerically controlled machines and the level of finish is as good as the best on the market.

Created to bring to market an innovative approach to problem solving combined with thoughtful design, first-class manufacturing and customer-facing marketing and logistics, we are based in Tuscany, Italy, in the heart of an area renowned for the excellence of its mechanical engineering.

PRODUCTS

Our range of standard products is described in this leaflet. However the range is increasing all the time, and updated information can be found on our website. Besides this we offer a full design service for the development, production and certification of custom solutions to specific problems.



OYSTER BUTTERFLY VALVE



OYSTER FLEXIVANE



OYSTER FLOWMASTER



OYSTER SAMPLEMASTER

VALVE BOLTED

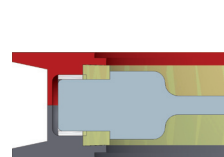

VBCC
CLAMP ABOVE
CLAMP BELOW

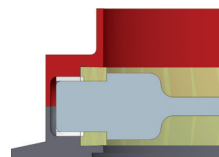

VBFC
FERRULE ABOVE
CLAMP BELOW

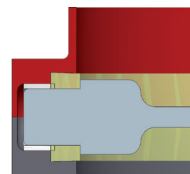

VBFW
FERRULE ABOVE
WAFFER BELOW

VALVE CLAMPED

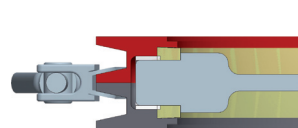

VCCC
CLAMP ABOVE
CLAMP BELOW

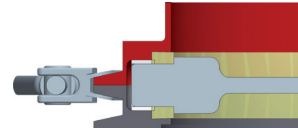

VCFC
FERRULE ABOVE
CLAMP BELOW

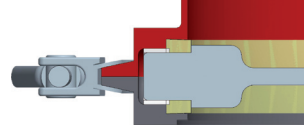

VCFW
FERRULE ABOVE
WAFFER BELOW

DISTRIBUTED BY



Powder Technologies, Inc
P. O. Box 780
Hainesport, NJ 08036, USA
E-mail: sales@powdertechusa.com
Web Site: www.powdertechusa.com
Tel: 1-609-914-0521, Fax: 1-609-914-0318

SOLUTIONS

You bring us your problem and we have the experience and the resources to provide a solution.

Our strong Engineering background means that all our products are fully compliant with all relevant regulations and certifications.

Our mission is to be supplier of first and last resort for Valves and accessories for powder handling in Pharmaceutical, Fine Chemical and other industries.

Our strength lies in our passion for innovation, our commitment to provide high quality products and service, and our culture of transparency and fair dealing with Customers, Suppliers and Staff.



ValvEngineering SRL
Via per Vicopelago 250GH
55057 Pontetetto (LU) - ITALY

Web: www.valvengineering.com
Email: info@valvengineering.com
T. & F.: +39 0583 370036

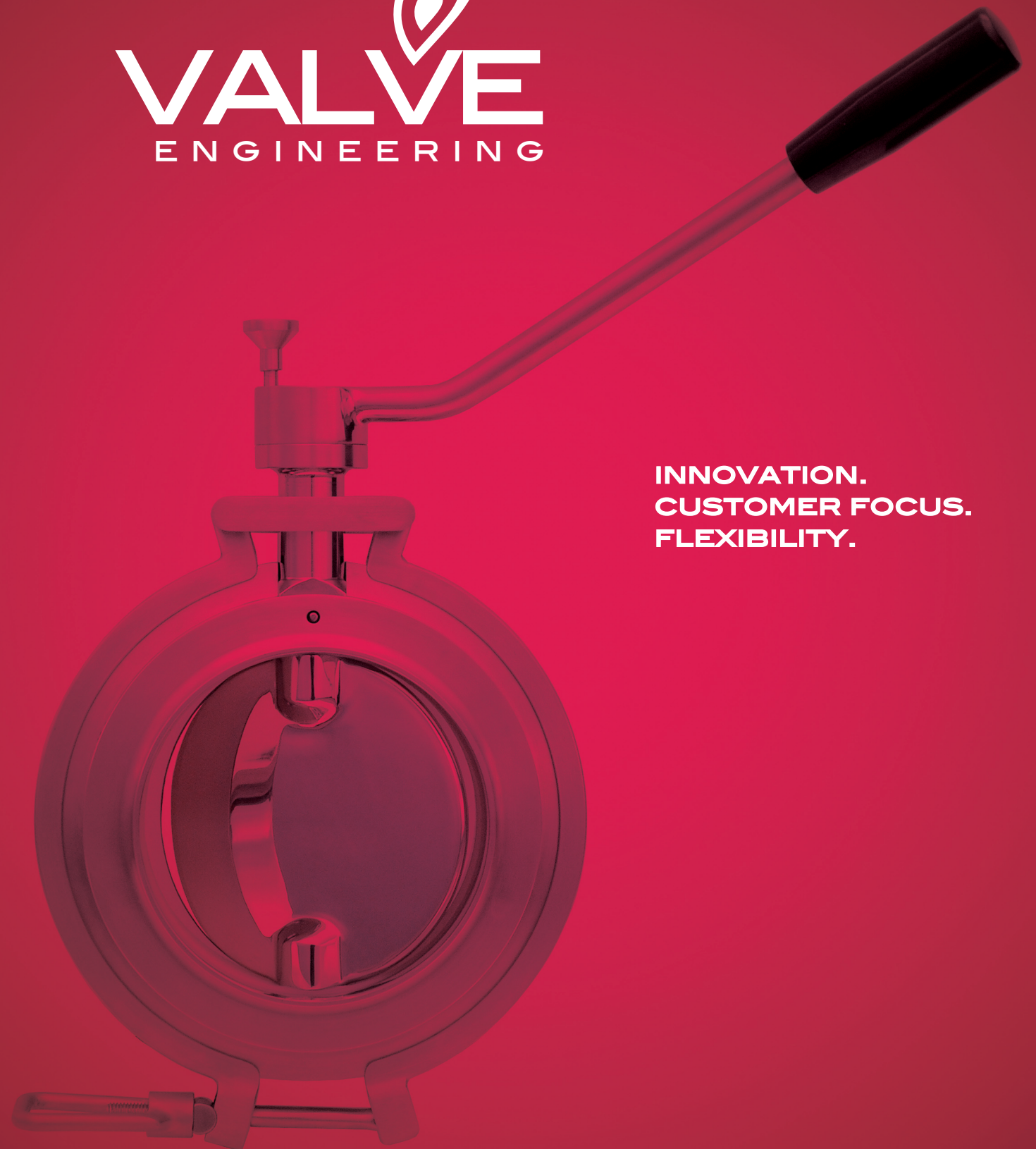

INNOVATION.
CUSTOMER FOCUS.
FLEXIBILITY.

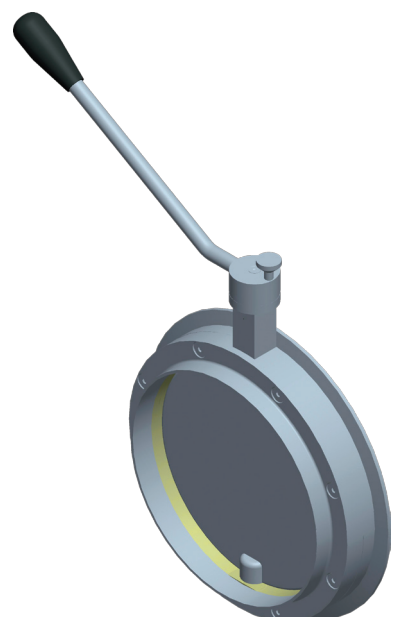

OYSTER BUTTERFLY VALVE

This is the standard butterfly valve developed for powder handling in the Pharmaceutical, Fine chemical, Cosmetics and Food Industries.

The Oyster butterfly valve has been designed to simplify cleaning and maintenance. It has no recesses with hard-to-clean corners, and is easily dismantled by one person using no special tools. Even better, the clever design allows for easy re-assembly even wearing gloves.

The valve design incorporates all current best practice so as to minimize weight and space (for example, our valve has a thicker seal than some of our competitors' which means a better performance under pressure as well as a lighter valve), and we have added a few tricks of our own such as titanium bolts as an option to eliminate the risk of seizing through over-tightening.

The valve body is fabricated from SS AISI 316L as standard but for applications with excessively corrosive substances we can

supply Hastelloy C22 as an alternative. All surfaces in contact with the product are polished to a mirror finish for maximum cleanliness.

Our standard gasket is precision moulded FDA-approved silicone but other FDA-approved elastomers can be supplied for particular applications – we will be glad to advise on the most appropriate solution.

The Oyster Butterfly valve can be supplied with a lever for manual operation or else fitted with Single- or Double-action pneumatic actuators as required. Other control accessories can be supplied on request.

We offer a full range of mounting options including Tri Clamp.

The Oyster Butterfly valve is ideal for handling: Powders, Granules, Gels or Liquids.

MATERIALS	
Valve body	AISI 316L, Hastelloy C22
Vane	AISI 316L, Hastelloy C22
Gasket	Silicone, EPDM
Bushes	PTFE
Clamp	AISI 304
Bolts	Titanium, AISI 304
Lever & mounting	AISI 304

FINISH OF STANDARD PRODUCT	
Internal	Mirror polished (Ra < 0.1 µm)
External	Satin (Ra < 0.6 µm)

Other finishes can be produced as options - ceramic sandblasting, electro-polished.

MAIN DIMENSIONS						
For Butterfly, Flexivane And Flowmaster Valves (BODY TYPE VBFC)						
ND	D1	D2	F	G	L	
100	180	150	45	65	140	
150	230	200	45	65	165	
200	280	250	45	65	190	
250	330	300	45	65	215	
300	380	350	45	65	240	

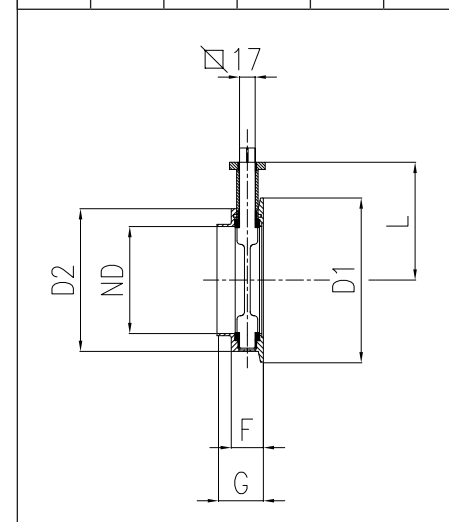

MATERIALS	
Valve body	AISI 316L
Vane	Silicone
Gasket	Silicone, EPDM
Bushes	PTFE
Clamp	AISI 304
Bolts	Titanium, AISI 304
Lever & mounting	AISI 304

OYSTER FLEXIVANE

The solid steel vane of the standard Butterfly valve can cause damage when used with tablets or capsules, if the product becomes trapped as the vane closes. The Oyster Flexivane has been designed to eliminate this problem by using a flexible vane formed from FDA-approved Silicone.

In common with all Oyster branded valves, the Oyster Flexivane has been designed to simplify cleaning and maintenance. As with the Oyster Butterfly it has no recesses with hard-to-clean corners, is easily dismantled by one person using no special tools and equally easily re-assembled - even wearing gloves.

All steel elements in contact with the product are machined from AISI 316L and polished to a mirror finish. The range of sizes available and the mounting options are as for the standard Oyster Butterfly valve.

The Oyster Flexivane can be supplied manually operated or fitted with single- or double-acting pneumatic actuator.

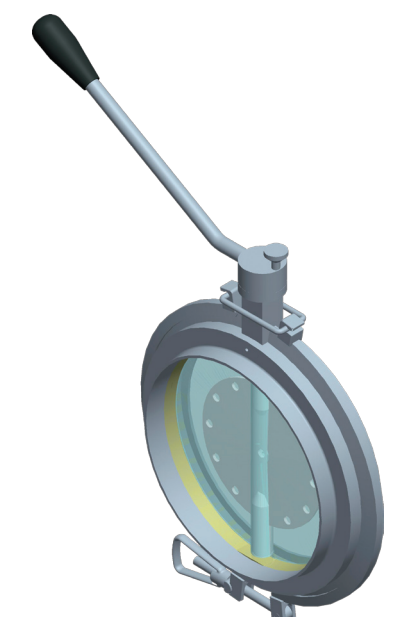

FINISH OF STANDARD PRODUCT	
Internal	Mirror polished (Ra < 0.1 µm)
External	Satin (Ra < 0.6 µm)

Other finishes can be produced as options - ceramic sandblasting, electro-polished.

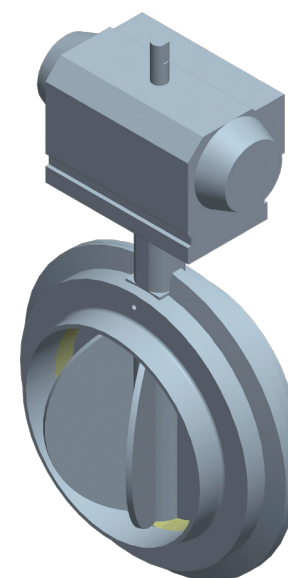

OYSTER FLOWMASTER VALVE

The Oyster Flowmaster is designed to enable an accurately controlled flow of material through the use of a gyrating spherical vane element. The pneumatically controlled movements of this spherical vane deliver a continuous uniform feed into machinery such as a weigh station, mill or tablet press. The form of the spherical vane can be varied to suit the requirements of the intended application and in particular the maximum/minimum flow rates, the stickiness of the material being handled and the degree of precision required.

The number of segments in the rotor is normally six, but it can be manufactured to order with eight or twelve.

The form of the rotor has been designed to minimise wear on the valve seat to reduce

maintenance, and to give a better closure.

In common with all Oyster branded valves, the Oyster Flowmaster has been designed to simplify cleaning and maintenance. As with the Oyster Butterfly valve it has no recesses with hard-to-clean corners, is easily dismantled by one person using no special tools and equally easily re-assembled - even wearing gloves.

All steel elements in contact with the product are machined from AISI 316L and polished to a mirror finish.

The range of sizes available and the mounting options are as for the standard Oyster Butterfly valve.

The Oyster Flowmaster valve is ideal for handling: Powders, Granules, Gels or Liquids.

FINISH OF STANDARD PRODUCT	
Internal	Mirror polished (Ra < 0.1 µm)
External	Satin (Ra < 0.6 µm)

Other finishes can be produced as options - ceramic sandblasting, electro-polished.

MATERIALS	
Valve body	AISI 316L
Rotor	AISI 316L
Gasket	Silicone, EPDM
Bushes	PTFE
Clamp	AISI 304
Bolts	Titanium, AISI 304
Actuator mounting	AISI 304

OYSTER SAMPLEMASTER VALVE

The Oyster Samplemaster has been designed to enable the easy and safe extraction of powder samples from machines such as mixers or driers.

The standard version is produced with all elements in contact with the product fabricated from AISI 316L which gives a high level of resistance to corrosion from all but the most aggressive products that are generally found in the pharmaceutical, fine chemical or food industries. Where even more exceptional performance is required then it can also be supplied in Hastelloy C22.

The Samplemaster valve features a patented "long-pitch" drive system to control the piston movement in such a way as to avoid wear to gaskets despite frequent use. It also has a special device designed to get around the problem of dried material caking the wall of the vessel.

To keep maintenance as simple as possible the Samplemaster valve is easily dismantled by one person with no special tools simply by releasing a TC clamp. This gives access to the surfaces in contact with the product which can then easily be cleaned and the valve re-assembled and returned to service.

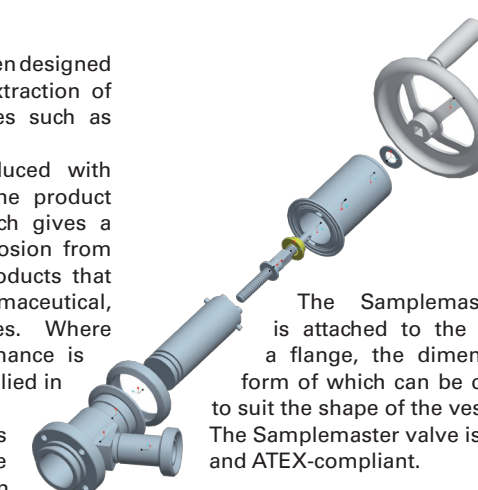

The Samplemaster valve is attached to the vessel via a flange, the dimensions and form of which can be customized to suit the shape of the vessel. The Samplemaster valve is fully PED- and ATEX-compliant.

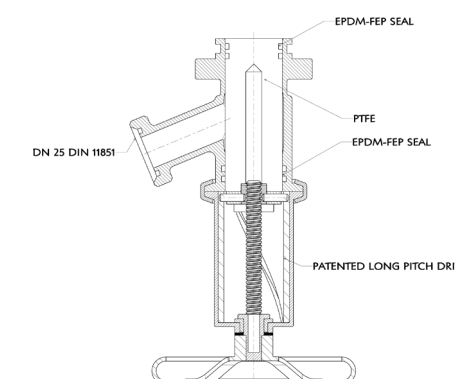
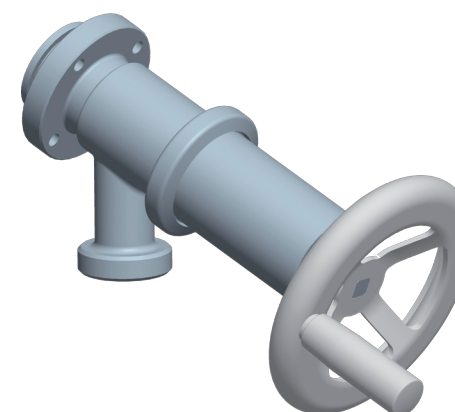

BODY MATERIALS
Available in AISI 316L or Hastelloy

DIMENSIONS
Dn 30 to Dn 80

WORKING PRESSURE
-0.5 to 6 Bars