

Gericke

Powder Processing Equipment & Systems

Efficient Quality Assured Centrifugal Sifters

High capacity, cost-effective
size separation



Gericke sifters
Capacities up to 100 tonnes per hour



Designed to Protect Product Integrity

Avoiding product contamination and ensuring the consistent quality of finished products, together with efficiency and reliability of operation, are becoming increasingly important in today's competitive markets.

Gericke have, for over 100 years, helped clients to satisfy their need to improve their powder handling processes and maximise revenue.

Developments in Gericke's latest generation of centrifugal sifters, enables manufacturers not only to increase productivity, but also to improve the quality of their final product.

Gericke have a unique international experience and have supplied centrifugal sifting machines to a vast range of industries. They can draw upon their extensive and exclusive library of applications to determine the best configurations for the process requirements.

Gericke sifters offer many advantages:

- High efficiency, high capacity sieving
- Robust construction
- Improved sealing arrangements for dust containment
- Hygienic construction
- Food quality seals and gaskets
- F.D.A. approved paint finishes
- Side-mounted drives for compact installation and adaptability
- Quick-change screens with no special tools required

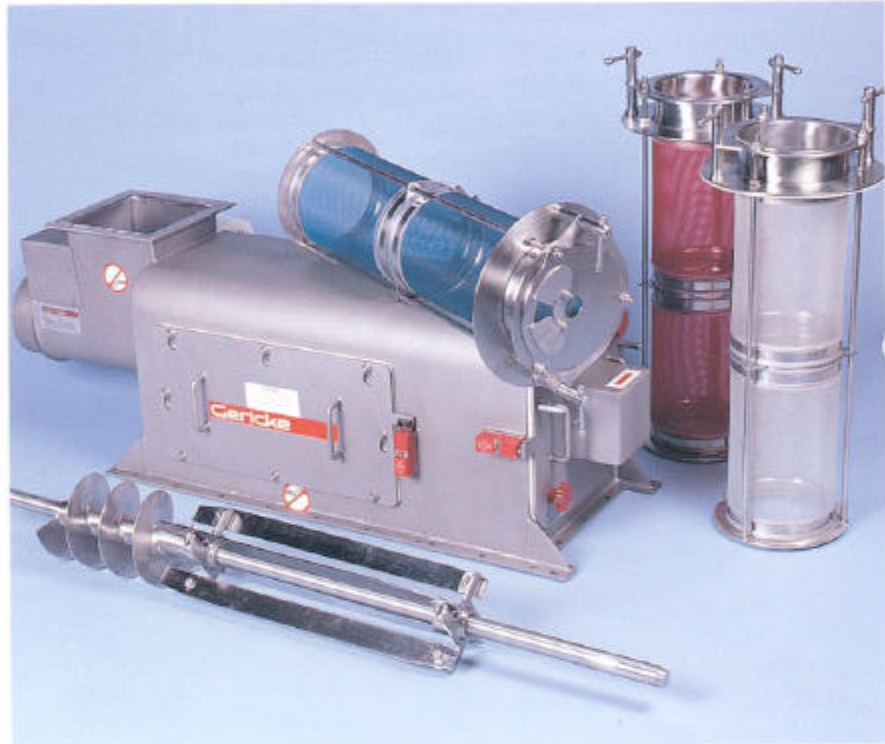

Screens

A comprehensive range of screen sizes are available ex-stock: including Nylon, Polypropylene and Woven Wire. Coloured screens are also available.

Typical Applications:

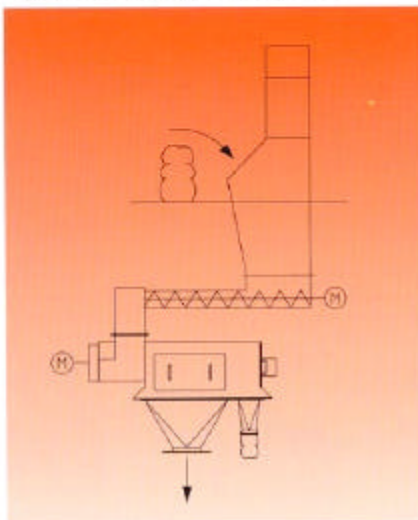

Check screening of raw materials.

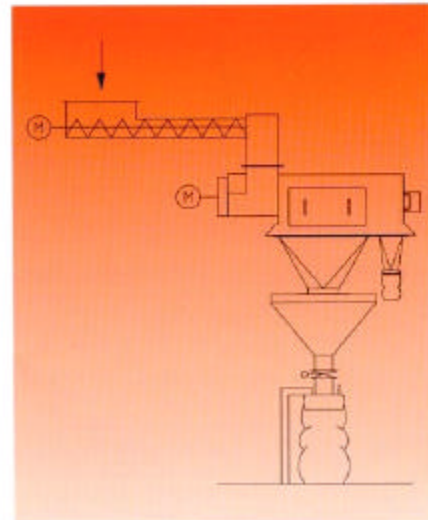

Sieving of finished product before packing.

Constructed to meet all needs

The standard range of Gericke Sifters includes four unit sizes: ranging from small laboratory applications, up to throughputs of 100 tonnes per hour.



Surface Finishes

Carbon steel machines are offered with F.D.A. approved paint as standard. Stainless steel units are supplied with a glass bead blast finish internally and externally. Special finishes, including polished surfaces up to 240 grit, are available and our specialists will advise on the most suitable for the application.

Customised Designs

- Twin Sifters
 - Gas purged seals
 - Pressure rated casings to 10 Bar
 - Pharmaceutical constructions
 - Machines suitable for electrically classified areas
 - Tumble Sifters
 - De-Dusting Applications
- * Please request current data sheets for installation planning



Special CSM 1542 Twin Sifter on final assembly

Standard options include:

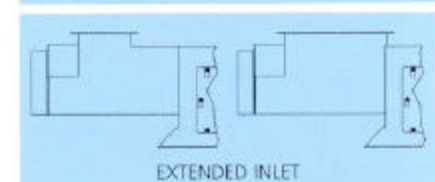
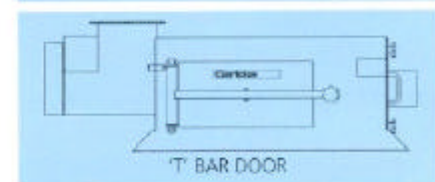
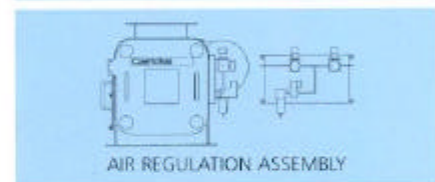
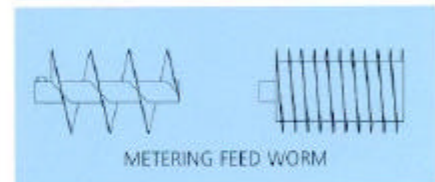
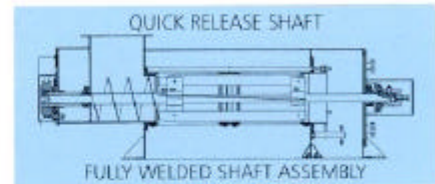

Proven Performance

Capacity graph for model CSM 722

(typical values)

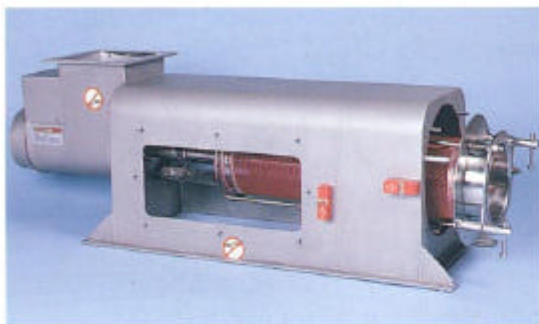
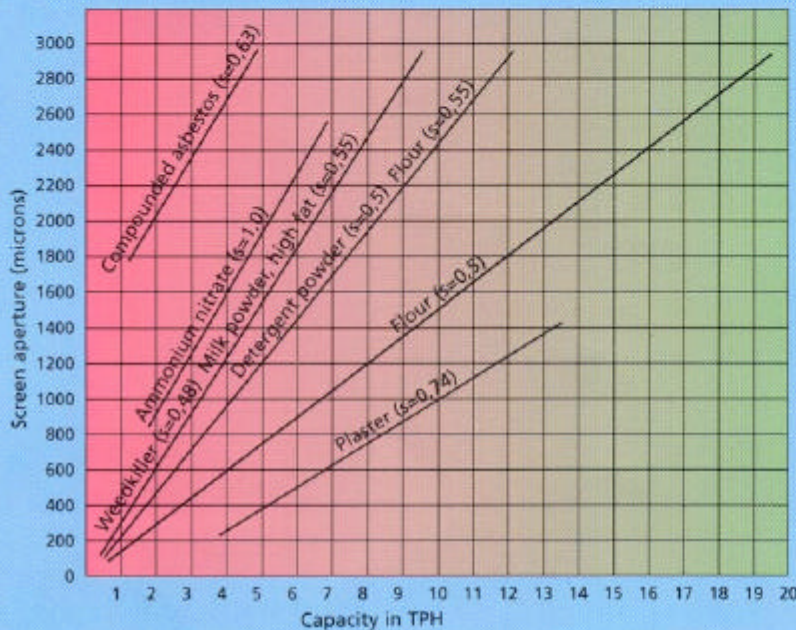

Relative capacities

- CSM 722 = 100%
- CSM 1130 = 200%
- CSM 1542 = 400%
- CSM 1542 Twin = 700%
- CSM 410 = 50%

Noise Level:-

70dba measured at one metre free field without product.

Application

Gericke sifters are almost universally applicable where dry materials are required to be separated by particle size.

Man-made fibre screens are available in a range from 55 micron to 5mm aperture and woven metal screens in aperture sizes from 2mm.

Capacities of Gericke sifters depend on the material to be processed and the aperture size of the screen selected.

If client requirements are not clearly definable based on our extensive experience, a trial in our dedicated test facility, on a production size machine, will enable us to make firm recommendations and offer suitable process guarantees.

Machines for trial at clients' premises are also available.

Gericke sifters are designed and manufactured utilising the most modern laser cutting technology and up to date process expertise.

Consult the specialists and find out how Gericke sifters can improve your final product.

Gericke

Powder Processing Equipment and Systems

Gericke Limited Victoria House, Cavendish Street, Ashton-under-Lyne, Lancashire OL6 7DJ.
Telephone: 0161-344 1140. Fax: 0161-308 3403.

Gericke Pte Limited 436 Tagore Avenue, Singapore 2678.
Telephone: 0065 4528133. Fax: 0065 4520392.

CH-8105 Regensdorf
NL-3870 Hoevelaken

D-78239 Rielasingen
F-95100 Argenteuil



Certificate No. 00695