

The cutting edge
in economical
size reduction

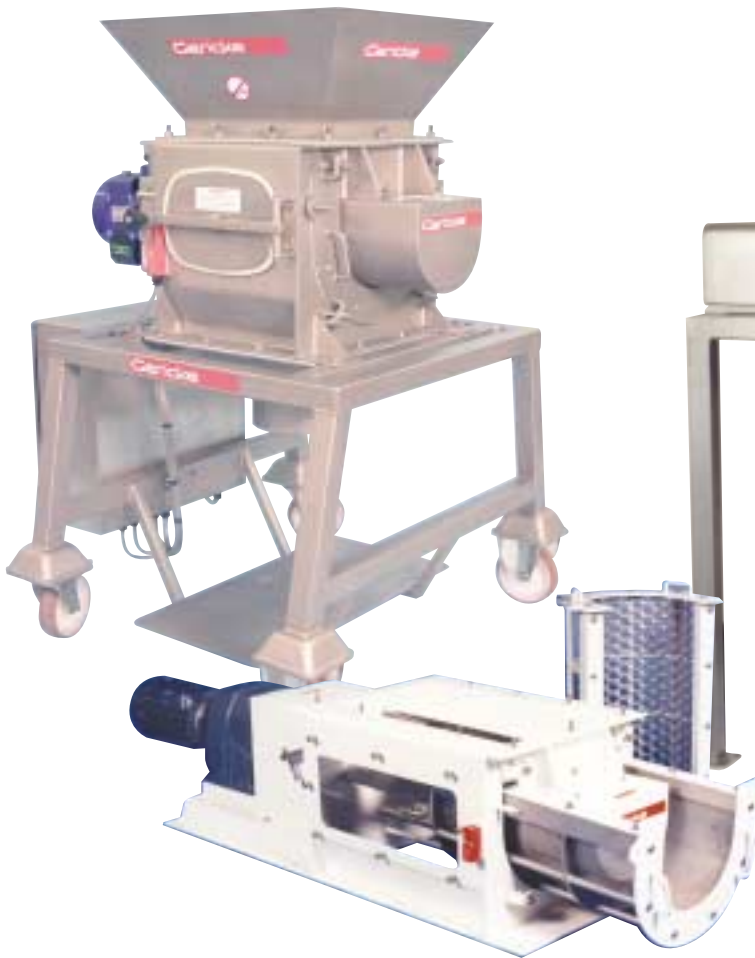

Size reduction systems
from 500mm to 150 micron

TYPICAL WORKING VALUES FOR NIBBLER RANGE

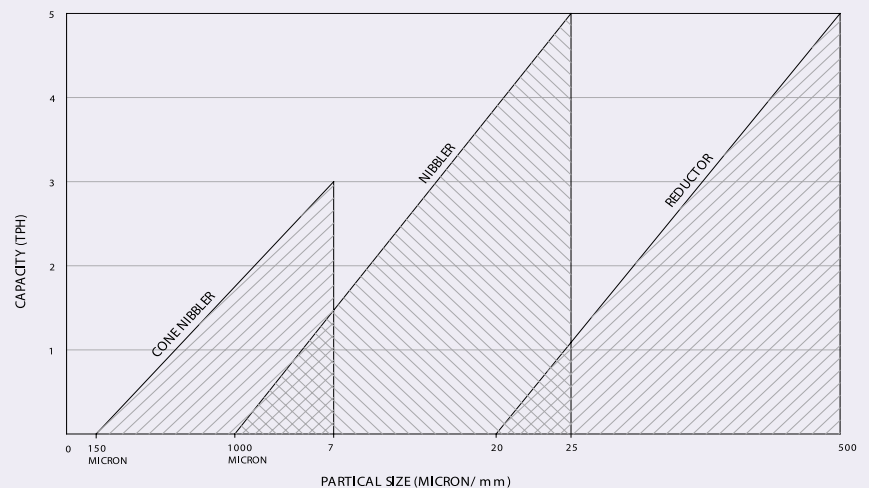

Gericke Nibblers; Simple, Flexible and Comprehensive Size Reduction.

The most effective method of particle size reduction has been a major consideration for solids handling processors for many years and in the past has traditionally involved the use of large scale equipment with high capital cost and energy requirements.

Today, Gericke Nibblers provide the ideal alternative. Cost effective, highly efficient solutions for coarse and fine size reduction and also the de-agglomeration of lumps.

The well proven Nibbler principle is based upon a cutting or grating action, as opposed to grinding and therefore the normal issues associated with size reduction such as temperature rise, noise and dust generation are minimised.

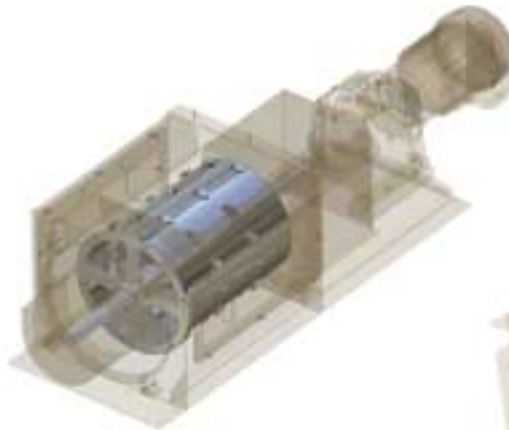

Gericke Nibbler offer many advantages:

- High capacity size reduction with low power consumption
- Minimal product temperature rise
- Robust compact construction
- Consistent particle size with little or no fines
- Low noise output: 65 dba measured at 1 metre free field without product
- Carbon and stainless steel options
- Food/Chemical
- Pharmaceutical/Hygienic Design

Key Advantages:

- Quick release basket and easy clean design.
- Dust tight access doors with safety switches
- Fixed bearing and seals to maximise component life
- Food quality seals
- Air purge seals
- Special/hazardous electrical specifications
- Atex Zone 22 and 21 compliant

Product Testing

Gericke Nibblers have been applied to handle many materials with vastly differing characteristics. Trials at one of our modern Test Facilities on production models will enable us to reproduce site conditions and combined with 35 years experience, offer recommendations and process guarantees.

A comprehensive fleet of rental machines located at Partner Companies around the World provide the opportunity to test products on site under production conditions.



The Reductor: Coarse Size Reduction. Particle Size Range: 500mm to 20mm

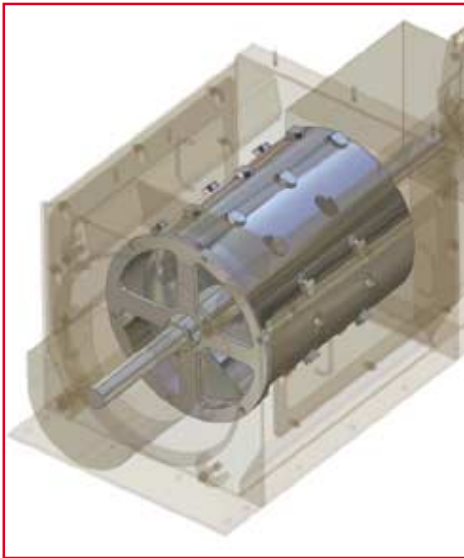

The Reductor is designed for pre-breaking blocks, lumps and slabs up to 500mm square with no restriction on the height of the material.

A rotor assembly complete with internal discharge screw and cutting teeth mounted onto the outside of the drum rotates slowly to reduce the blocks to approximately 25mm pieces.

Holes cut into the rotor body around the teeth allow the reduced pieces to pass into the discharge screw and out of the machine.

The Reductor does **NOT** require a metered feed and can be used in combination with a Nibbler to produce a granular finished product from large blocks in a single pass.

Particle Size Range: 500mm - 20mm

- Two standard machine sizes:
300 x 450 and 450 x 700
- Teeth size: 25 and 75 mm
- Heavy duty casing, rotor, cutting teeth and drive
- Carbon steel and stainless steel contact part options
- Side cleaning door(s) with safety switch
- Quick release end door with safety switch



Reductor Rotor Assembly

Consisting of a compact heavy duty casing, the assembly includes side inspection doors with safety switches, end door for access to the rotor and a geared motor unit which can be used with a frequency inverter to vary the rpm of the machine.

| Typical Applications | Products Processed | |
|--|--|--|
| <ul style="list-style-type: none"> ■ Pre-breaking raw materials prior to dissolving or melting ■ Reduction of blocks before secondary size reduction ■ Reprocessing/reclaiming scrap materials ■ Processing surface hardened materials ■ Combination size reduction with Nibblers, Cone Nibblers and Mills ■ Opening polythene, cellophane coated paper and carton packages up to 0.5 kg for reworking contents. | <ul style="list-style-type: none"> Acetic Acid Animal Feed Boiled Sweets Caramel Ceramics Chemicals Chocolate Block Coal Tar Pitch Cocoa Liquor Block | <ul style="list-style-type: none"> Fat Blocks Hard Paraffin Wax Hard Toffee Fillings Natural Gum Peat Block Pnenolic Resin PVC Floor Covering Resin |

The Nibbler: Medium Size Reduction. Particle Size Range 25mm - 1mm

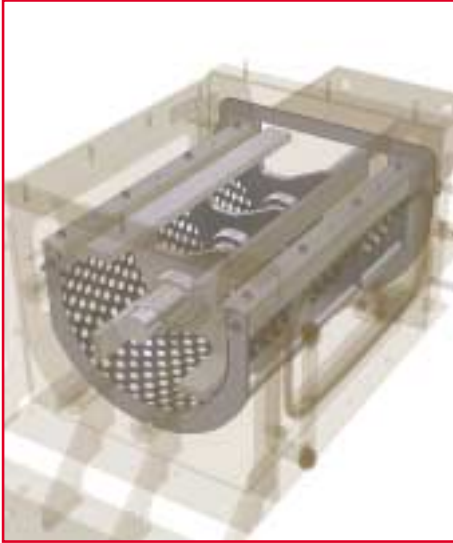

A gravity feed of product enters the nibbler which uses a low speed high torque rotating paddle assembly to sweep the material across a static serrated screen, inducing a cutting or grating action.

The gap between the rotor blade and screen is fully adjustable and this movement together with a frequency inverter, used to change the rpm of the rotor, optimises the performance of the machine to deal with different material characteristics and to provide a controlled output feed with consistent particle size, without the production of excessive fines.

Screen sizes range between 25mm and 1mm and are available in different configurations to suit the product and required particle size.

A quick release clamping arrangement allows the basket assembly to be completely removed for screen changes, cleaning and maintenance.

The range includes five standard sizes which are selected on throughput requirement and initial particle size. Special machines up to 3 metres long are available.

Other options include jacketed units for heating, drying and cooling, 10 bar construction, heavy duty drives and mobile assemblies.

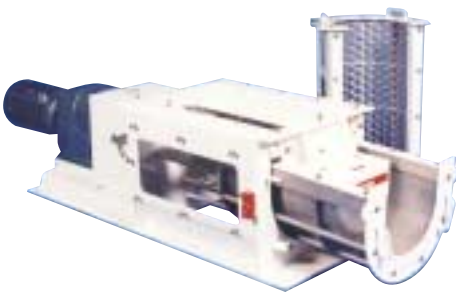

Quick release basket assembly

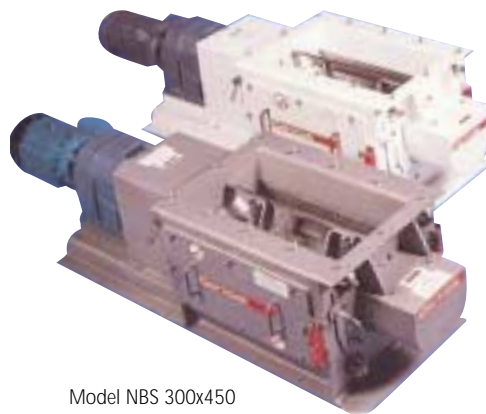

Model NBS 300x450
Carbon steel and stainless steel
options

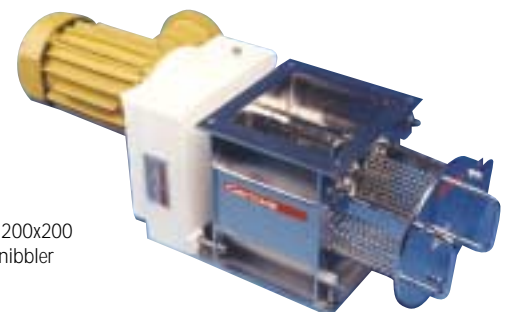

Model NBS 200x200
Hygienic nibbler

Particle Size Range: 25mm - 1mm

- Five standard machine sizes:
200 x 200, 300 x 350, 300 x 450,
300 x 800 and 450 x 800
- Quick release basket assembly with safety switch
- Side cleaning door(s) with safety switch.
- Fixed bearing and seal assembly
- Food quality seals and hygienic design
- Air purge seals
- Carbon steel and stainless steel contact part options
- Pressure rated casings
- Heating/cooling jackets
- FDA paint, bead blast and polished finishes

Screen Sizes

Standard sizes 1.1, 1.5, 2, 3, 4, 5, 6, 7, 8, 10, 14, 18, 20 and 25 mm



Model NBS 300 x 350
Mobile Nibbler Assembly

| Typical Applications | Products Processed | |
|---|---|---|
| <ul style="list-style-type: none"> ■ De-agglomeration after drying, spraying and mixing ■ After storage in silo's, big bags, sacks, drums and containers where compaction may occur ■ Before secondary processing including milling, grinding and feeding ■ Before pneumatic or mechanical conveying ■ Reprocessing/reclaiming of oversize or off-spec materials ■ After wide band driers up to 3 metres long | <ul style="list-style-type: none"> Activated Carbon Briquettes Agrochemicals Aluminium-Magnesium Biscuits Bread Dough Ceramic Waste Charcoal Cheese Chocolate Crumb Cocoa Powder Lumps Detergent Powder | <ul style="list-style-type: none"> Epoxy Resins Granulated Sugar Latex Milk Powder (50% Fat) Pesticides Plastics Roasted Nuts Soap Flakes Wax Whey Powder |

The Cone Nibbler: Fine Size Reduction. Particle Size Range 6mm - 150 micron

The Cone Nibbler incorporates a vertically mounted rotating tool which moves the material across a conical static serrated screen introducing a low velocity high impact cutting action into the product which is fed by gravity into the machine.

Sub screen size product passes through the screen into the chamber while oversize particles not reduced by the first pass are carried by the vortex action of the tooling up towards the inlet returning it into the cutting chamber until the desired particle size distribution is achieved.

Different hole patterns, shapes and screen sizes ranging from 12mm to 150 micron are available and when used with a frequency inverter, the most efficient running settings are achieved.

Gericke Cone nibblers include a unique patented fully adjustable top mounted rotor to cone gap adjuster which allows the setting to be made from outside the cutting chamber without opening the machine.

A hinged lower section with quick release clamp and micro switch allows easy access for screen changes, cleaning and maintenance.



Model GCN Cone Nibbler



Rotor gap adjustment



Quick release cutting chamber

Particle Size Range: 6 mm - 150 micron

- Three standard machine sizes: 150, 300 and 450
- Quick release access to cutting chamber with safety switch
- Fully adjustable gap between rotor and screen
- Top adjustment of rotor gap from outside of machine
- Gap adjustment indicator
- Quick release rotor assembly
- Air purge seals
- Food quality seals
- Screen options range from 150 micron to 12 mm with various hole patterns.

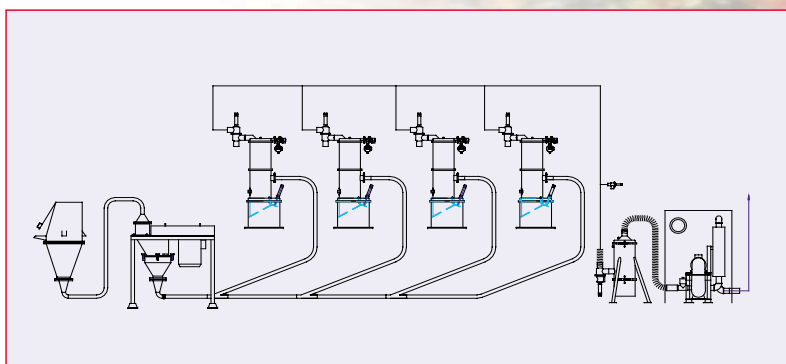

IN-LINE CONE NIBBLER IN VACUUM CONVEYING SYSTEM

Options

- In-line unit suitable for installation into Dilute Phase Conveying Systems
- Pressure rated casings (10 Bar)
- Variable speed drives
- Mobile units

| Typical Applications | Products Processed | |
|---|--|---|
| <ul style="list-style-type: none"> ■ Fine size reduction for finished products and intermediate components ■ Close tolerance particle size distribution ■ Processing dry, moist, fatty, sticky and heat sensitive materials ■ Dry and wet granulation after high shear mixers and fluid bed driers ■ Reclaiming tablets and capsules ■ In-line processing with pneumatic and mechanical conveying systems | <ul style="list-style-type: none"> ■ Animal Feed ■ Agglomerated Milk Powder ■ Biscuits ■ Boiled Sweets ■ Bread Crumb ■ Brown Sugar ■ Cocoa Powder ■ Dyestuffs ■ Granulated Sugar ■ Lead Based Resin ■ Malto-Dextrin | <ul style="list-style-type: none"> ■ Pectin ■ Pesticides ■ Pharmaceutical Granulate ■ Potassium Chloride ■ Rusk ■ Salt ■ Starch ■ Tablets/Capsules ■ Wood Chip ■ Wood Flour |

"The Perfect Partnership"



For over 100 years Gericke's mission has been to provide individual components and to build innovative turnkey systems to meet the demands of the bulk solids process industry.

Made by Gericke has become an international watchword for quality, value and reliability.

Our unrivalled range of technologies, experience and dedication to customer service makes Gericke the perfect partner for all your powder processing requirements.

Gericke's comprehensive range of services include:

Bulk Storage Systems, IBC and FIBC Systems, Discharging, Pneumatic Conveying, Sieving and Sifting, Feeding, Mixing, Size Reduction, Process Control, Product Testing, Project Management, Installation, Commissioning & After Sales Service.

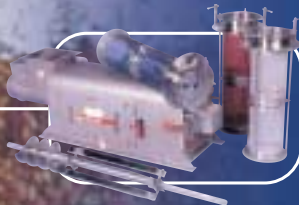

CENTRIFUGAL SIFTER:

- 8 models
- Up to 100tph



IN-LINE SIFTER:

- Positive pressure
- Vacuum Conveying



FEEDERS:

- Volumetric
- Gravimetric



RA DISCHARGERS:

- Silos
- Hoppers/day bins



PNEUMATIC CONVEYING:

- Dense phase
- Blowing/vacuum



BATCH MIXING:

- GMS multi flux
- Plough share/ribbon

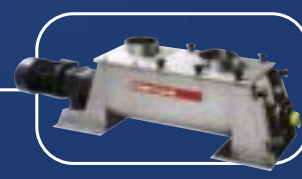

CONTINUOUS MIXING:

- Powder blending
- Granulation